

**Cat® 3512B Land Electric-Drive Drilling Module
with Dynamic Gas Blending™ (DGB™)
Oil & Gas**



**1045 ekW/1492 kVA
1101 bkW/1476 bhp
60 Hz/1200 rpm**



Picture shown may not reflect actual configuration

Specifications

Cat® 3512B Land Electric-Drive Drilling Module with DGB™	Metric	Imperial (English)
Configuration	V-12, 4-Stroke-Cycle Diesel	
Emissions	Non-certified	
Bore	170 mm	6.69 in
Stroke	190 mm	7.48 in
Displacement	52 L	3158 in ³
Aspiration	Turbocharged-Aftercooled	
Fuel System	EUI™	
Engine Control and Protection	ADEM™ A4	
Generator	SR4B	
Voltage	600V	
Instrumentation	EMCP 4.4	

Features

Dynamic Gas Blending™

- Achieves up to 70% substitution while maintaining diesel performance and safe engine operation
- Closed loop control system enables maximum substitution over the widest load range in the industry
- Maintains traditional diesel drilling module power and transient response performance
- Accepts a wide range of gas quality and automatically adjusts to fuel quality changes, eliminating the need for field calibration
- EMCP 4.4 control panel features simplified rig integration, remote monitoring capabilities, and single-point interface for the engine, generator, and Dynamic Gas Blending functions
- Leverages current hardware from G3512 product line while minimizing change to core diesel engine
- Maintains existing diesel maintenance and overhaul intervals proven in oilfield applications

Engine Design

- Market-leading power density
- Proven reliability and durability
- Robust design prolongs life and lowers owning and operating costs
- Long overhaul life proven in oilfield applications
- Core engine components designed for reconditioning and reuse at overhaul

Safety

- E-Stop pushbutton on instrument panel
- Air shutoff and explosion relief valves
- Configurable alarm and shutdown features
- Extra alarm switches available for customer-supplied inputs
- Flame arrestors

Ease of Installation and Packaging

- EMCP 4.4 control panel uses standard communication protocols to integrate easily with rig monitoring equipment to track engine health and substitution performance
- Paralleling and load sharing capability

- Diesel and gas controls fully integrated into single engine control unit
- Single-point operation for engine, generator, and Dynamic Gas Blending system
- Dynamic Gas Blending system automatically activates when gas supply is detected

Custom Packaging

For any petroleum application, trust Caterpillar to meet your project needs with custom factory generator sets and mechanical packages. Cat engines, generators, controls, radiators, and transmissions can be custom designed and matched in collaboration with our local dealers to create unique solutions. Custom packages are globally supported and are covered by a one-year warranty after startup.

Testing

Every unit is full-load tested to ensure proper performance

Product Support Offered Through Global Cat Dealer Network

- More than 2,200 dealer outlets
- Caterpillar factory-trained dealer technicians service every aspect of your Cat product
- Worldwide parts availability, service, and warranty
- Preventive maintenance agreements available for repair-before-failure options

S•O•SSM program matches your oil and coolant samples against Caterpillar set standards to determine:

- Internal engine component condition
- Presence of unwanted fluids and combustion by-products
- Site-specific oil change interval

Over 80 Years of Engine Manufacturing Experience

The Caterpillar Production System enables manufacturing of products with the highest quality standards for long and dependable operation.

Web Site

For all your petroleum power requirements, visit www.cat.com/oilandgas

Configuration

Air Inlet System

Corrosion-resistant aftercooler core

Air inlet shutoff

Air cleaner options:

- *Regular duty
- Heavy duty

+ Remote air inlet adapter – round 305 mm (12 in)

Control System

ADEM A4 ECU, left-hand mounted

Engine control options:

- *Direct rack control 0-200 mADC, space heater and jacket water heater connection and controls
- Direct rack control 0-200 mADC with 6 stator RTDs, 2 bearing RTDs, space heater and jacket water heater connection and controls
- Cat DVR control, includes reactive droop capability, 3-phase voltage sensing, kVAR/PF modes, RFI suppression, min/max exciter limiter and exciter diode monitor, space heater and jacket water heater connection and controls, 6 stator RTDs, 2 bearing RTDs

Cooling System

Separate-circuit aftercooled

Outlet controlled jacket water thermostat

Jacket water pump – gear driven

Dual outlet

Aftercooler water pump – gear driven

Aftercooler water thermostat

Radiator options:

- *Caterpillar supplied radiator, 46/CVD 0.520 ratio, includes blower fan, fan drive, pulley, belt guard, coolant level sensor, regulator, and fuel cooler
- Remote cooling connection RH
- Remote cooling connection LH
- Customer provided radiator
- Custom radiator

Cooling system connection options (for use with customer-supplied radiator):

- Dual outlet coupling-type connections
- Dual outlet hose and clamp-type connections

Fan drive and belt guard (for use with remote and customer-supplied radiators)

Fan pulley options (for use with remote and customer-supplied radiators):

- Front stub shaft
- Front stub shaft with 197 mm pulley
- Front stub shaft with 248 mm pulley
- Custom

+ Blower fan, 1829 mm (72 in) (for use with customer supplied radiator)

+ Blower fan, 1829 mm (72 in) high pitch (for use with customer-supplied radiator)

+ Jacket water inlet adapter

Exhaust System

Dry exhaust manifold

Dual turbochargers, water cooled bearings

Weldable exhaust flanges (2), 250.95 mm

+ Elbow, 356 mm (14 in)

+ Muffler, 356 mm (14 in), spark arresting, includes companion flanges, clean-out box, and spark box

Flywheel and Housing

SAE No. 00 flywheel

SAE No. 00 flywheel housing

SAE standard rotation

Fuel System (Diesel)

Fuel transfer pump

Fuel return line with flexible connection

Electronic unit injectors

Fuel filter options:

- *Fuel filter simplex (LH) with priming pump (LH)
- Custom fuel filter

+ Primary fuel filter

+ Primary fuel filter with water separator

Generator Attachments

RTDs platinum, 2 per phase

Space heater – 1200 watt

Droop CT (1) – 2000/5

Sensing CTs (3) –2000/5

Generator terminal box options:

- Barrel-mounted petroleum terminal box
- *Barrel-mounted petroleum terminal box with air filter and pressure differential switch

+ Cable access box

+ Low voltage extension box

*Denotes which option is included in the standard configuration

+ Optional attachment

Configuration (continued)

Instrumentation

Emergency stop button

Analog gauges:

- Fuel pressure
- Engine oil pressure
- Engine oil temperature
- Engine coolant temperature
- DC voltage
- Engine percent load

EMCP 4.4 control panel

- 5.5 inch graphical display
- 16 languages supported
- Engine/generator monitoring and protection
- CAN, RS 485 MODBUS, Ethernet communications supported
- Remote e-stop/start/stop
- Engine start and crank attempt counter

Thermocouples, one per cylinder

Voltage indicator

Lubrication System

Crankcase breather

Oil cooler

Shallow oil pan

Oil drain extension, 2 in NPT female connection

Oil filter options:

- *Simplex oil filter
- Custom oil filter

Centrifugal oil filter options:

- RH installed centrifugal oil filter
- *No centrifugal oil filter included

Lubricating oil options:

- SAE15W40, Caterpillar DEO™, 500 hour
- *No lubricating oil included

Fumes disposal options:

- *Fumes disposal system
- No fumes disposal included

Crankcase fumes disposal

*Manual prelube pump

+ Oil level regulator

Mounting System

Inner base options:

- *4.19 m (165 in) length, 412 mm (16.2 in) height tubes, 1.18 m (50.5 in) wide
- Custom base

Outer base options:

- *No outer base included
- Custom outer base

+ Package isolator supports (3), for mounting inner base to customer-supplied base

Power Take-off

+ Charging alternator, 24V, 60A

Protection System

Alarms:

- ECU voltage
- Oil pressure
- Low/high water temperature
- Overspeed
- Crankcase pressure
- Aftercooler temperature
- Low water level (optional)
- Air inlet restriction
- Exhaust stack temperature
- Oil/fuel filter differential pressure

Derate:

- High water temperature
- Crankcase pressure
- Aftercooler temperature
- Air inlet restriction
- Exhaust temperature

Shutdown:

- Oil pressure
- Low/high water temperature
- Overspeed
- Crankcase pressure
- Aftercooler temperature

Air inlet shutoff options:

- *Air inlet shutoff, electrical
- Air inlet shutoff, hydra-mechanical (custom)
- No air inlet shutoff

Metal particle detector options:

- *Metal particle detector switch
- Metal particle detector with annunciator
- No metal particle detector

+ Explosion relief valves

Starting System

Starting motor options:

- *TDI air starting motor, RH – 1034 kPa (150 psi)
- Custom starting motor
- Dual electric/air starters

+ 24V battery set

+ Battery rack

+ Air pressure regulator

General

+ Jacket water heater

*Denotes which option is included in the standard configuration

+ Optional attachment

Technical Data

	Units	EM0735 – Diesel Mode EM0736 – DGB Supplement
Module Data		
Rated power***	ekW	1045
kVA rating	kVA	1492
Rated power factor		0.7
Frequency	Hz	60
Engine Data		
Engine power	bkW (bhp)	1101 (1476)
Engine speed	rpm	1200
Max. altitude without derate (@ 25°C)	m (ft)	2000 (4921)
BMEP @ rated	kPa (psi)	2127 (309)
Gas fuel pressure	kPag (psig)	83-241 (12-45)
Gas fuel flow, maximum (@ 32MN)*	MJ/hr (BTU/min)	3358 (53,065)
Gas fuel flow, maximum (@ 45MN)*	MJ/hr (BTU/min)	4384 (69,272)
Gas fuel flow, maximum (@ 65MN)*	MJ/hr (BTU/min)	7154 (113,056)
Gas fuel flow, maximum (@ 85MN)*	MJ/hr (BTU/min)	7751 (122,492)
Max diesel BSFC (diesel mode @ 100% load)	g/bkW-hr (lb/bhp-hr)	208 (0.34)
Air flow rate	m³/min (ft³/min)	89 (3157)
Inlet manifold pressure	kPa (psi)	266 (39)
Inlet manifold temperature	°C (°F)	72 (161)
Aftercooler water temperature	°C (°F)	60 (140)
Jacket water temperature	°C (°F)	99 (210)
Exhaust stack temperature**	°C (°F)	488 (911)
Exhaust flow rate (@ stack temp, 101.3 kPa)	m³/min (ft³/min)	222 (7823)
Engine coolant capacity	L (gal)	157 (41)
Lube oil system capacity	L (gal)	318 (84)
Oil change interval	Hours	500
Generator Data		
Generator Model		SR4B
Frame size		867
Voltage (L-L)	Volts	600
Insulation class		H
Coastal insulation protection		Included
Temperature rise (@ 40°C ambient temp)	°C	80
Excitation		SE/PM
Number of poles		6
Winding		Form wound
Pitch		7.33
Number of leads		6
Number of bearings		2
Ingress protection (IP) rating		23
Alignment		Close coupled

Note: Reference the A&I guide for specific gaseous fuel requirements

*At rated load and maximum substitution

**Maximum 32MN-85MN gas at rated

***Does not include fan power

Altitude and Ambient Capability

Ambient Operating Temp (°C)	0	10	20	25	30	40	50
Altitude (m)	(% Power at Ambient and Altitude)						
0 m	1.00	1.00	1.00	1.00	1.00	1.00	1.00
500 m	1.00	1.00	1.00	1.00	1.00	1.00	1.00
1000 m	1.00	1.00	1.00	1.00	1.00	1.00	1.00
1500 m	1.00	1.00	1.00	1.00	1.00	1.00	1.00
2000 m	1.00	1.00	1.00	1.00	1.00	0.97	0.94
2500 m	0.99	0.99	0.97	0.96	0.94	0.91	0.88
3000 m	0.95	0.95	0.92	0.90	0.88	0.86	0.83

Engine Heat Rejection (32-85 MN Gas)

Percent Load	Engine Power		Jacket Water		Aftercooler		Exhaust		Atmosphere	
	bkW	bhp	kW	Btu/min	kW	Btu/min	kW	Btu/min	kW	Btu/min
100	1101	1476	484	27,525	266	15,127	1340	76,219	143	8110
75	826	1108	382	21,724	174	10,451	992	55,884	106	6034
50	550	738	280	15,923	87	4,948	696	39,563	72	4098
25	275	369	174	10,357	20	1,137	418	23,324	40	2255

EMCP 4.4 Features

140 mm (5.5 in) Graphical Display

- Generator AC voltage
 - 3-phase (L-L & L-N)
 - ± 0.25% accuracy
- rpm and battery voltage
- Generator AC current (per phase and average)
- Generator frequency
- Power metering (kW, kVA, kVAr, pf)
- Hour meters (kW-hour, kVAr-hour)
- Engine oil pressure (psi, kPa or bar)
- Engine oil temperature (°C or °F)
- Engine coolant temperature (°C or °F)
- Multiple language support
- Engine start and crank attempt counter
- Real time clock

Communication

- Accessory CAN data link
- RS-485 annunciator data link
- RS-485 SCADA (Modbus RTU)
- Ethernet SCADA (Modbus TCP)

Controls

- Auto/start/stop
- Engine cooldown timer
- Emergency stop
- Engine cycle crank
- Programmable cycle timer
- Paralleling up to eight units

Drilling Module Protection

- Over/under voltage
- Over/under frequency
- Generator phase sequence
- Over current (timed and inverse)
- Reverse kW, kVA
- Current balance
- Bus phase sequence
- Low oil pressure
- High coolant temp
- Low coolant level
- Fail to start
- Overspeed

Outputs

- 17 programmable digital outputs
- 3 programmable (4-20mA or ±10V)
- 2 programmable (PWM)

Inputs

- Emergency stop
- Remote start
- 12 programmable digital inputs
- Oil pressure and water temperature
- 4 programmable inputs (±10V, PWM, current, or resistive)
- Oil temperature, fuel level

Other Features

- 16 languages supported:
 - Arabic
 - Chinese
 - Danish
 - Dutch
 - English
 - Finnish
 - French
 - German
 - Greek
 - Italian
 - Japanese
 - Portuguese
 - Russian
 - Spanish
 - Swedish
 - Turkish
- Programmable security levels
- Reduced power mode
- Programmable kW relay
- Cat switchgear integration
- Status event log

Dimensions

LAND ELECTRIC-DRIVE DRILLING MODULE

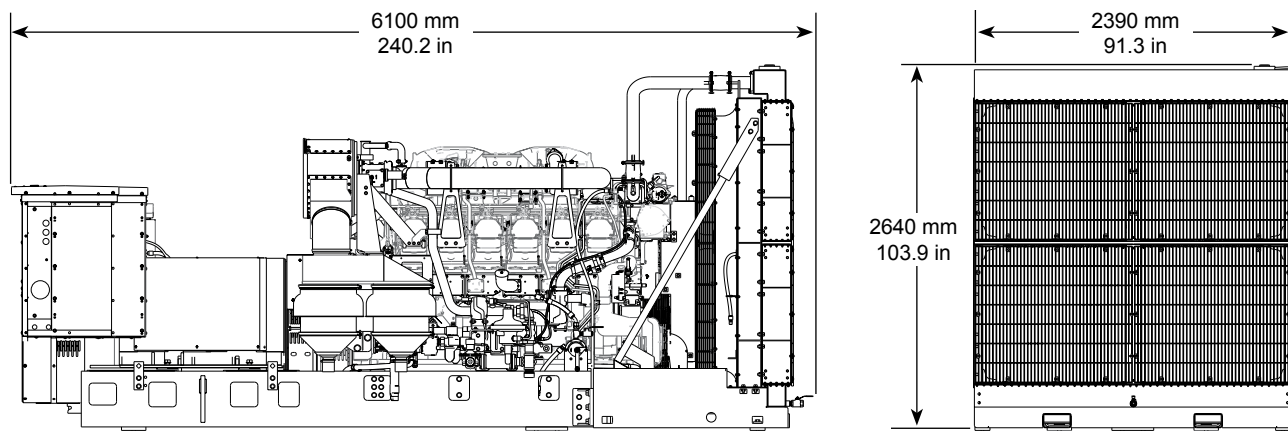

Dimensions and Weight		
Length	6100 mm	240.2 in
Width	2390 mm	91.3 in
Height	2640 mm	103.9 in
Module Weight (dry)*	12 854 kg	28,279 lb

Do not use for installation design. See installation drawing for details.

*Drilling module weight includes engine, generator, and base.

Rating Definitions and Conditions

Drilling-Electric Rating – Output available with varying load for an unlimited time. Prime power in accordance with ISO8528. Typical load factor 60-70%.

Conditions – Performance is obtained and corrected in accordance with ISO 3046/1. Reference atmospheric inlet air: 100 kPa (29.61 in Hg), 25°C (77°F), 30% relative humidity at stated aftercooler temperature. Performance is also in accordance with SAE J1995, BS5514/1, and DIN6271/1 standard reference conditions.

Diesel Fuel – Reference fuel is #2 distillate diesel with a 35 degree API gravity, lower heating value is 42 780 kJ/kg (18,390 Btu/lb) when used at 29°C (84.2°F), where the density is 838.9 g/L (7.001 lb/gal).

Gaseous Fuel – Reference natural gas has a lower heating value of 33.74 kJ/L (905 BTU/cu.ft.). Low energy ratings are based on 18.64 kW/L (500 BTU/cu.ft.) lower heating value gas. High energy gas ratings are based on 87.56 kJ/L (2350 BTU/cu.ft.) lower heating value gas.

©2015 Caterpillar
All rights reserved.

Materials and specifications are subject to change without notice.
The International System of Units (SI) is used in this publication.

CAT, CATERPILLAR, their respective logos, Dynamic Gas Blending, DGB, DEO, EUI, ADEM, S•O•S, "Caterpillar Yellow," the "Power Edge" trade dress as well as corporate and product identity used herein, are trademarks of Caterpillar and may not be used without permission.